

1 MTS 80-60 R36 D8.6



Screw spindle pump designed for pumping of cooling lubricants and cutting oils water/oil emulsion min. 3% for machine tool applications. The pump is designed to be mounted on top of tanks with pump immersed in the pumped liquid.

The pump has the following characteristics:

- High efficiency ensures very low heat input into the cooling lubricant.
- Axial thrust completely neutralised hydrostatically.
- Very wear resistant due specially hardened surfaces.
- D8.6 - mechanical shaft seal according to EN 12756.
- Power transmission via cast iron flexible coupling.

The motor is a 3-phase AC motor.

:	:	Emulsion
:	:	80 °C
:	:	20 °C
:	:	998.2 kg/m <sup>3</sup>
:	가	: 3500 rpm
1	:	105 l/min
가:	:	D8.6
:	:	CE,EAC
:	:	60 °C
:	:	60 bar
:	:	SAE 2"
:	:	G 1 1/4" / SAE 1 1/2"
:	:	0 mm
:	:	FF300
IE	:	160MD
	:	IE2 - IE3
	- P2:	15 kW
	(P2):	14.9 kW
	:	60 Hz
	:	3 x 380-480D/660-690Y V
	:	28,0-22,4/16,2-15,6 A
	:	580-890 %
cos phi -	:	0.90-0.86
:	:	3520-3550 rpm

: IE2 90,2% - IE3 91,0%  
: 90.2-91.0 %  
3/4 : 92.4 %  
1/2 : 92.4 %  
: 2  
(IEC 34-5): 55 Dust/Jetting  
(IEC 85): F  
:  
: 154 kg

# MTS 80-60 R36 D8.6 60 Hz

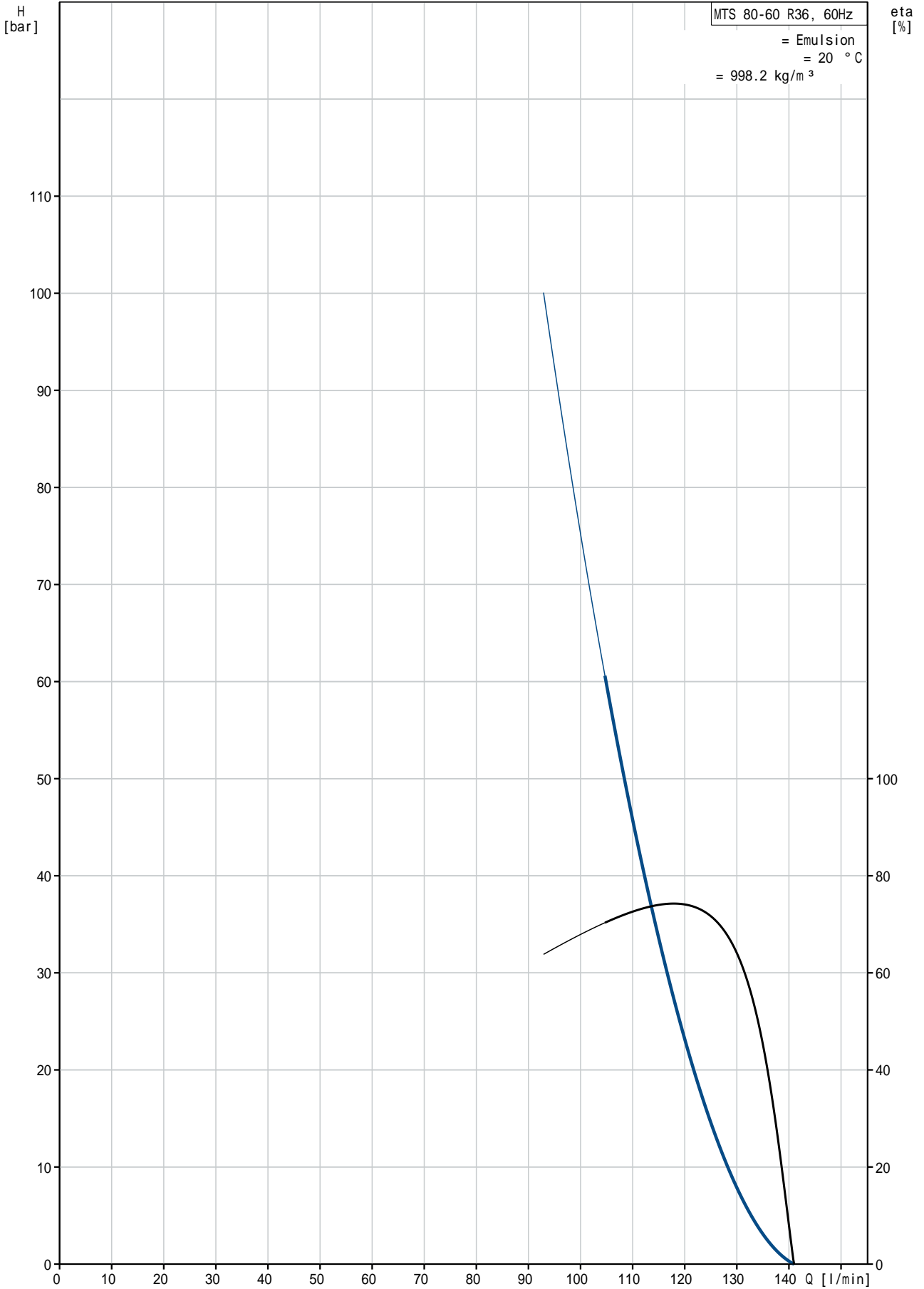

MTS 80-60 R36 D8.6	
EAN	
가	3500 rpm
	105 l/min
1	D8.6
가:	CE, EAC
	A
	60 °C
	60 bar
	SAE 2"
	G 1 1/4" / SAE 1 1/2"
	0 mm
	FF300
	Horizontal
	Emulsion
	80 °C
	20 °C
	998.2 kg/m <sup>3</sup>
	160MD
IE	IE2 - IE3
- P2:	15 kW
(P2):	14.9 kW
	60 Hz
	3 x 380-480V/660-690V V
	28,0-22,4/16,2-15,6 A
	580-890 %
cos phi -	0.90-0.86
	3520-3550 rpm
	IE2 90,2% - IE3 91,0%
	90.2-91.0 %
3/4	92.4 %
1/2	92.4 %
	2
(IEC 34-5):	55 Dust/Jetting
(IEC 85):	F
	PTC
	87420022
Pos term	12 o'clock
	154 kg
	3 %
	36

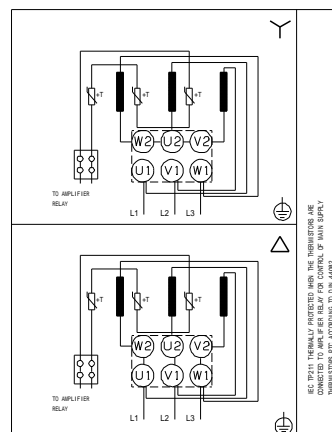
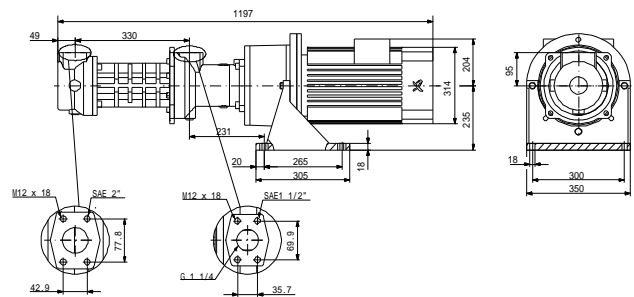
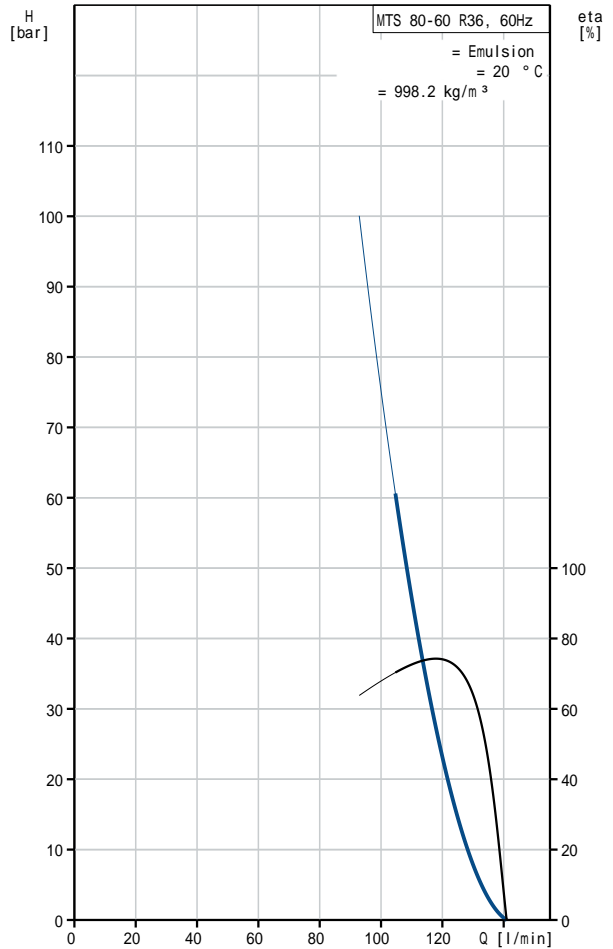

MTS 80-60 R36 D8.6 60 Hz

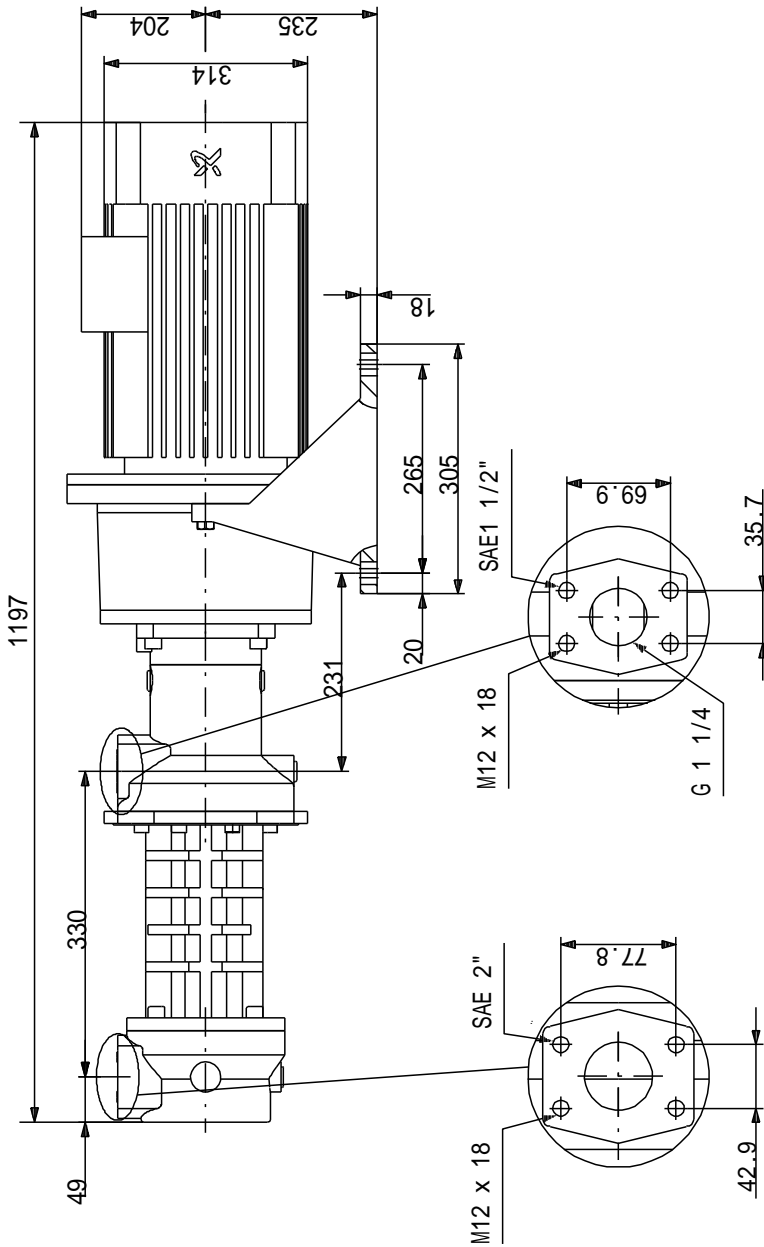
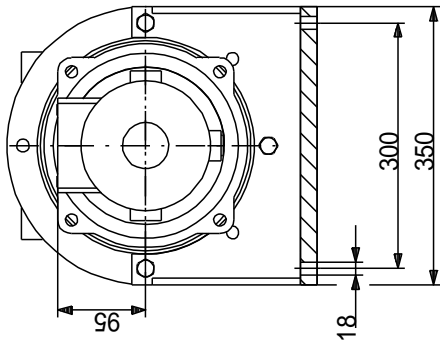

!

[mm]

MTS 80-60 R36 D8.6 60 Hz

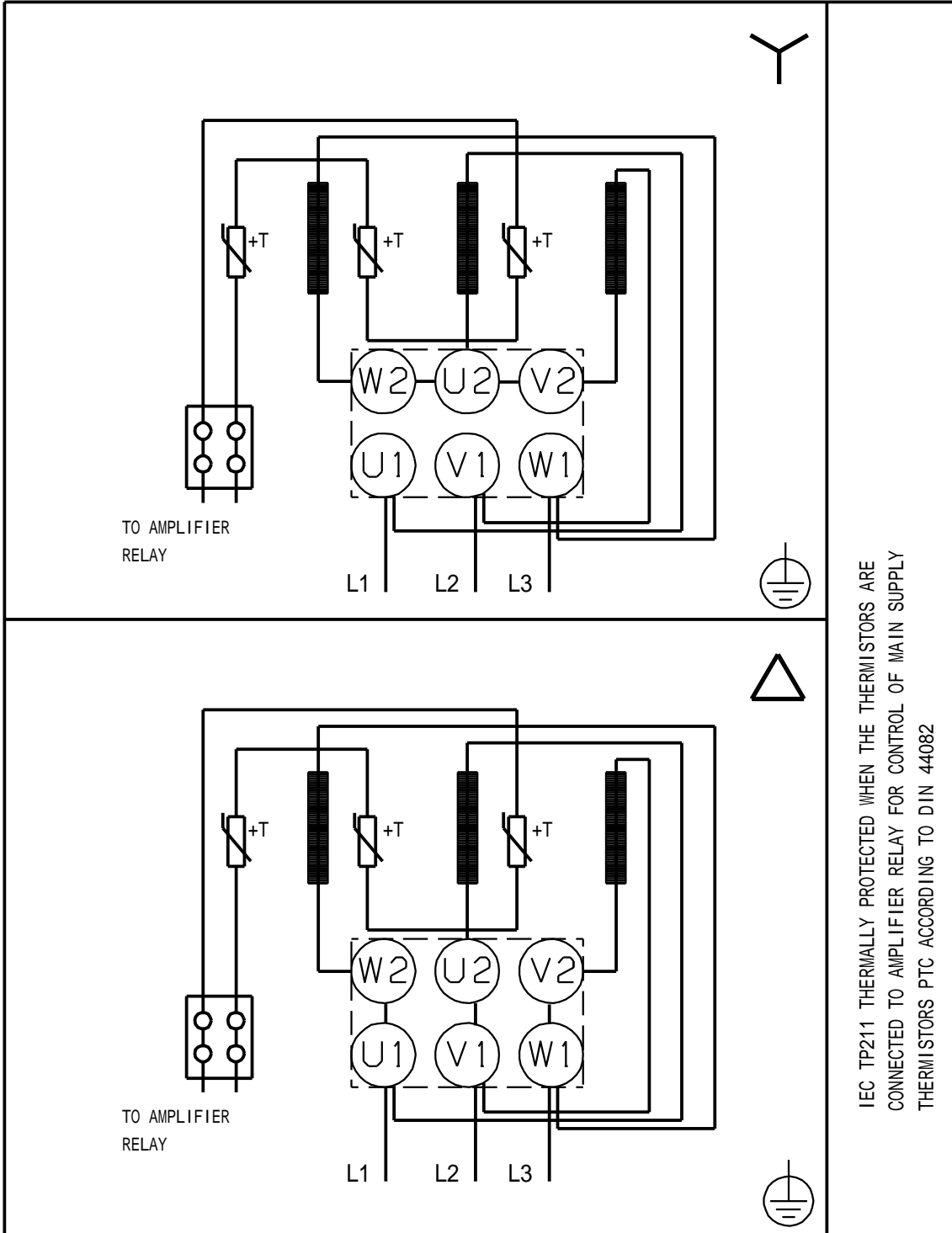

IEC TP211 THERMALLY PROTECTED WHEN THE THERMISTORS ARE  
CONNECTED TO AMPLIFIER RELAY FOR CONTROL OF MAIN SUPPLY  
THERMISTORS PTC ACCORDING TO DIN 44082