

1 MTS 80-70 R36 D8.6



Screw spindle pump designed for pumping of cooling lubricants and cutting oils water/oil emulsion min. 3% for machine tool applications. The pump is designed to be mounted on top of tanks with pump immersed in the pumped liquid.

The pump has the following characteristics:

- High efficiency ensures very low heat input into the cooling lubricant.
- Axial thrust completely neutralised hydrostatically.
- Very wear resistant due specially hardened surfaces.
- D8.6 - mechanical shaft seal according to EN 12756.
- Power transmission via cast iron flexible coupling.

The motor is a 3-phase AC motor.

:	:	Emulsion
:	:	80 °C
:	:	20 °C
:	:	998.2 kg/m ³
:	가	: 3500 rpm
1	:	102 l/min
가:	:	D8.6
:	:	CE,EAC
:	:	60 °C
:	:	70 bar
:	:	SAE 2"
:	:	G 1 1/4" / SAE 1 1/2"
:	:	0 mm
:	:	FF300
IE	:	160LB
- P2:	:	IE2 - IE3
(P2):	:	18.5 kW
:	:	17.2 kW
:	:	60 Hz
:	:	3 x 380-480D/660-690Y V
:	:	34,5-28,0/20,0-16,6 A
cos phi -	:	670-1100 %
:	:	0.89-0.84
:	:	3520-3560 rpm

: IE2 91,0% - IE3 91,7%
: 91.0-91.7 %
3/4 : 93.2 %
1/2 : 93.2 %
: 2
(IEC 34-5): 55 Dust/Jetting
(IEC 85): F
:
: 167 kg

MTS 80-70 R36 D8.6 60 Hz

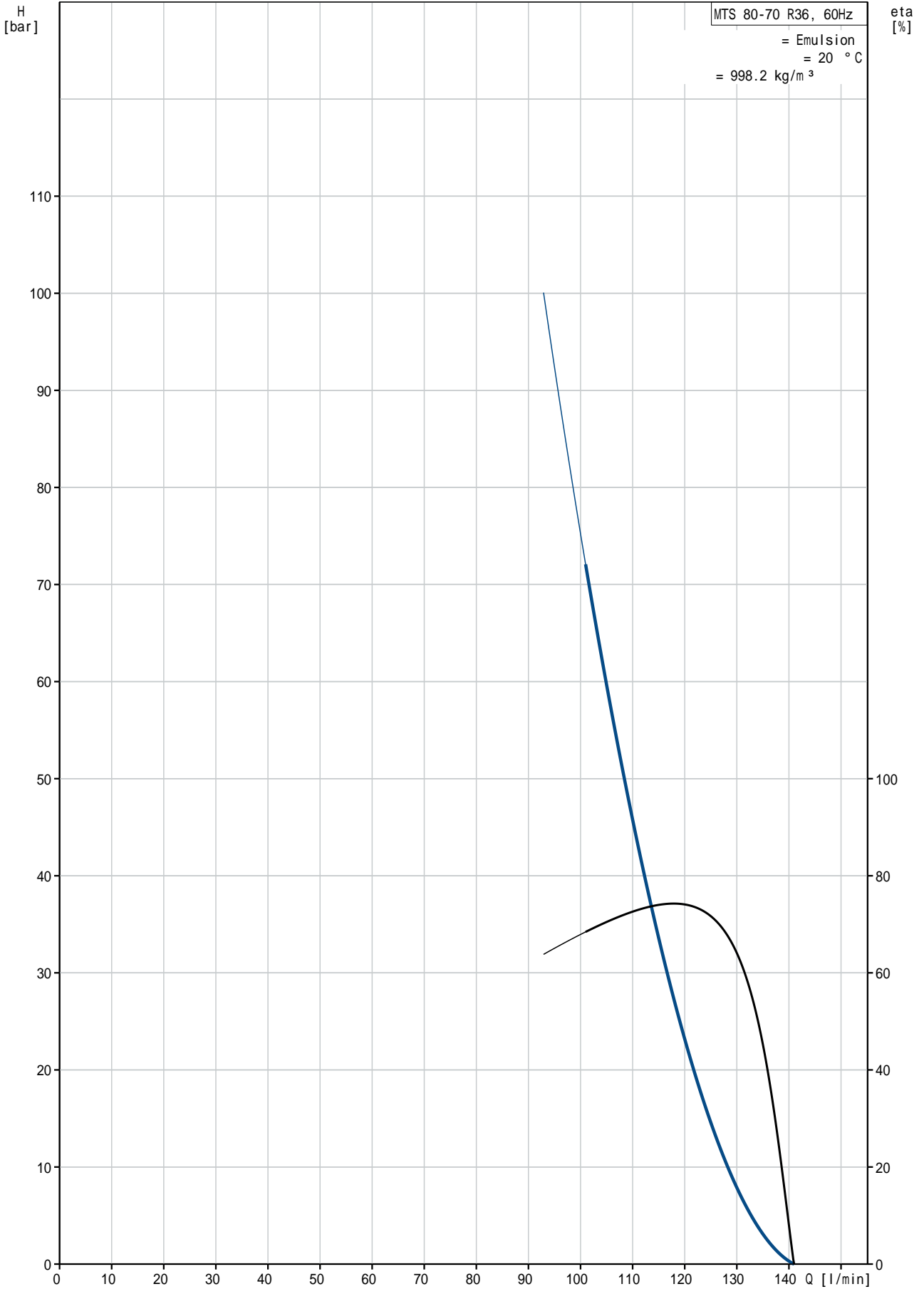

MTS 80-70 R36 D8.6	
EAN	
가	3500 rpm
	102 l/min
1	D8.6
가:	CE, EAC
	A
	60 °C
	70 bar
	SAE 2"
	G 1 1/4" / SAE 1 1/2"
	0 mm
	FF300
	DRY
	Emulsion
	80 °C
	20 °C
	998.2 kg/m ³
	160LB
IE	IE2 - IE3
- P2:	18.5 kW
(P2):	17.2 kW
	60 Hz
	3 x 380-480V/660-690V V
	34,5-28,0/20,0-16,6 A
	670-1100 %
cos phi -	0.89-0.84
	3520-3560 rpm
	IE2 91,0% - IE3 91,7%
	91.0-91.7 %
3/4	93.2 %
1/2	93.2 %
	2
(IEC 34-5):	55 Dust/Jetting
(IEC 85):	F
	PTC
	87420023
Pos term	12 o'clock
	167 kg
	3 %
	36

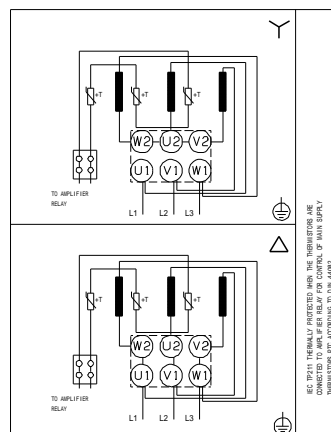
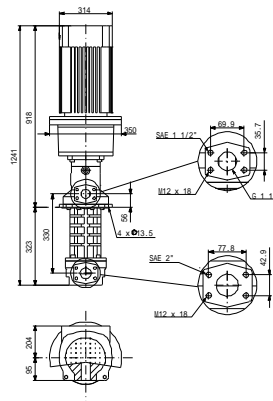
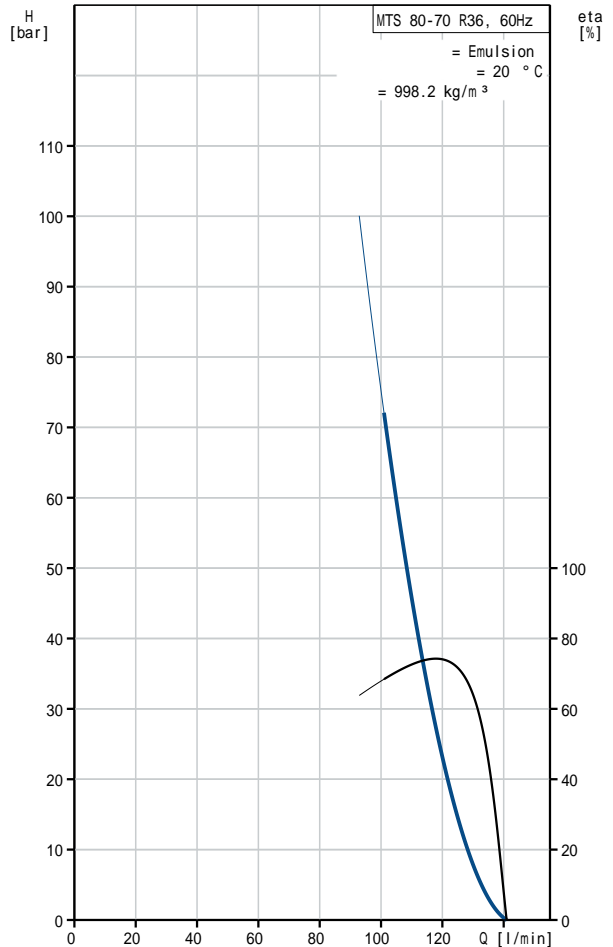

MTS 80-70 R36 D8.6 60 Hz

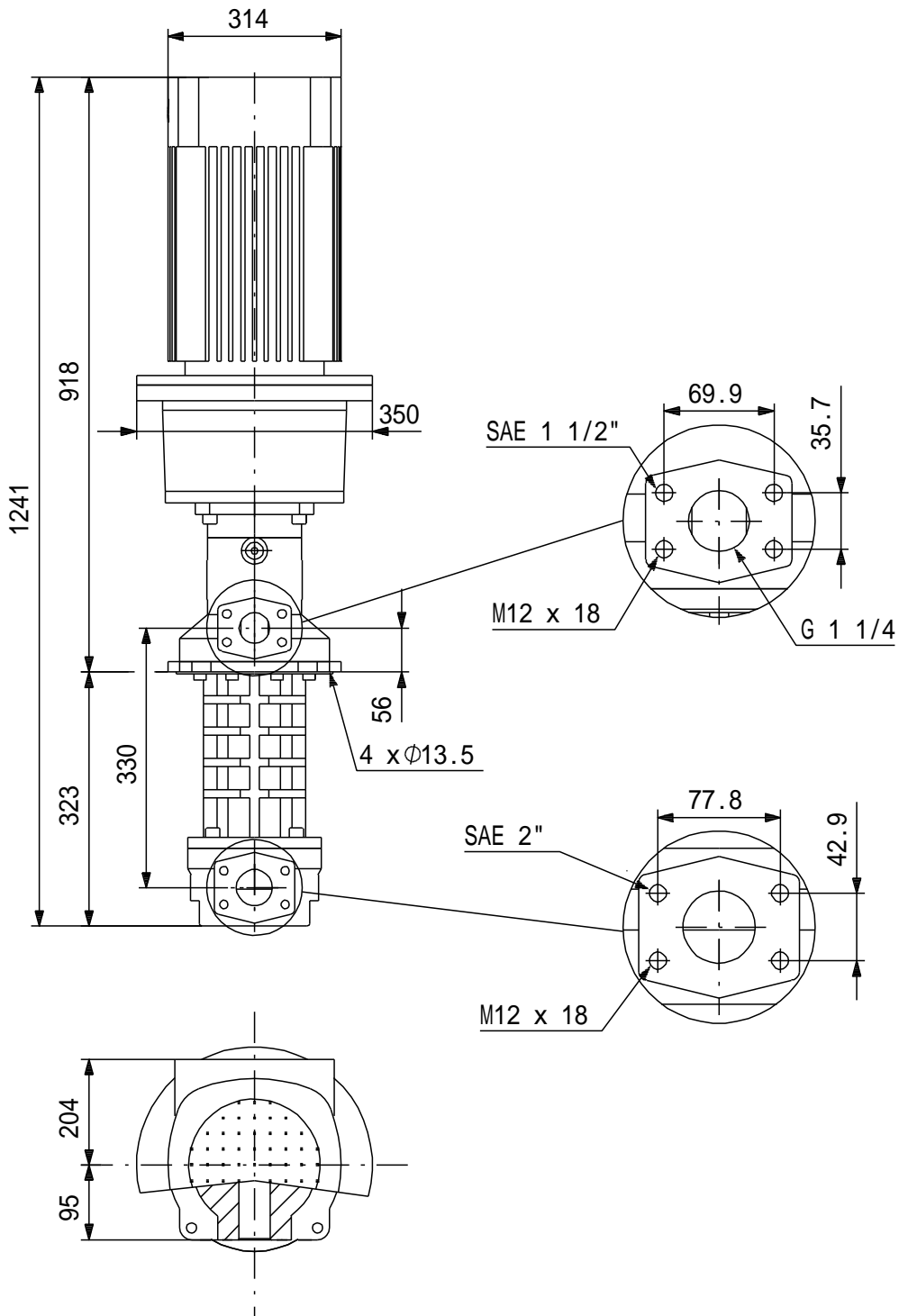

!

[mm]

MTS 80-70 R36 D8.6 60 Hz

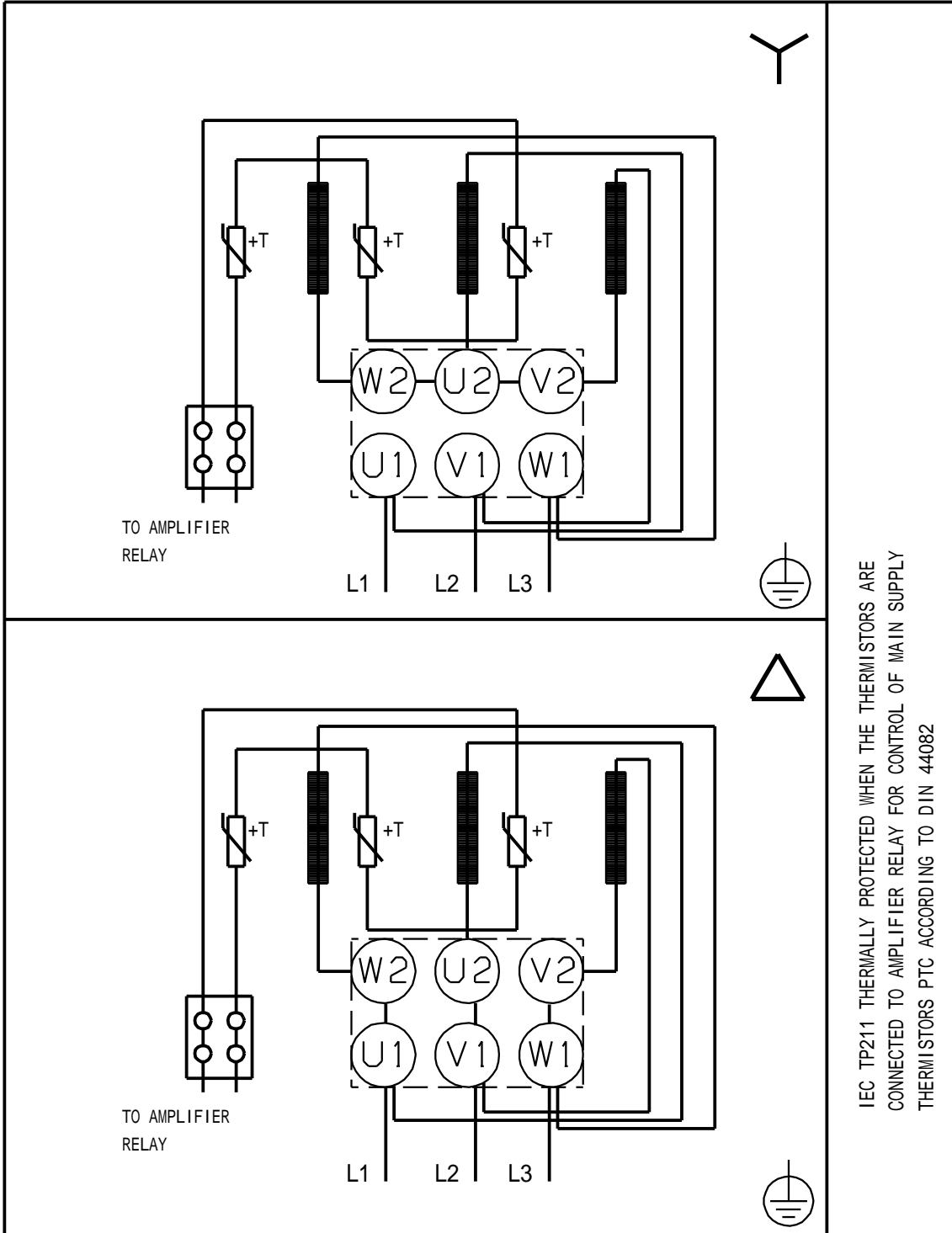

IEC TP211 THERMALLY PROTECTED WHEN THE THERMISTORS ARE
CONNECTED TO AMPLIFIER RELAY FOR CONTROL OF MAIN SUPPLY
THERMISTORS PTC ACCORDING TO DIN 44082