

1 MTS 80-100 R36 DQ



Screw spindle pump designed for pumping of cooling lubricants and cutting oils water/oil emulsion min. 3% for machine tool applications. The pump is designed to be mounted on top of tanks with pump immersed in the pumped liquid.

The pump has the following characteristics:

- High efficiency ensures very low heat input into the cooling lubricant.
- Axial thrust completely neutralised hydrostatically.
- Very wear resistant due specially hardened surfaces.
- DQ - shaft seal ring.
- Power transmission via cast iron flexible coupling.

The motor is a 3-phase AC motor.

:	:	Emulsion
:	:	80 °C
:	:	20 °C
:	:	998.2 kg/m ³
:	:	
:	가	: 3500 rpm
1	:	92.9 l/min
:	:	DQ
가:	:	CE
:	:	
:	:	55 °C
:	:	100 bar
:	:	G2"
:	:	G 1 1/4" / SAE 1 1/2"
:	:	335 mm
:	:	FF350
:	:	
IE	:	SIEMENS
:	:	NEMA Premium / IE3 60Hz
- P2:	:	30 kW
(P2):	:	24.2 kW
:	:	60 Hz
:	:	3 x 380-420D/660-725Y V
:	:	56,0-50,0/32,0-29,0 A
:	:	610-610 %
cos phi -	:	0.89
:	:	3545 rpm
:	:	IE3 92,4%
:	:	92.4-92.4 %
3/4	:	92.8-92.8 %
1/2	:	92.5-92.5 %
:	:	2
(IEC 34-5):	:	55 Dust/Jetting

MTS 80-100 R36 DQ 60 Hz

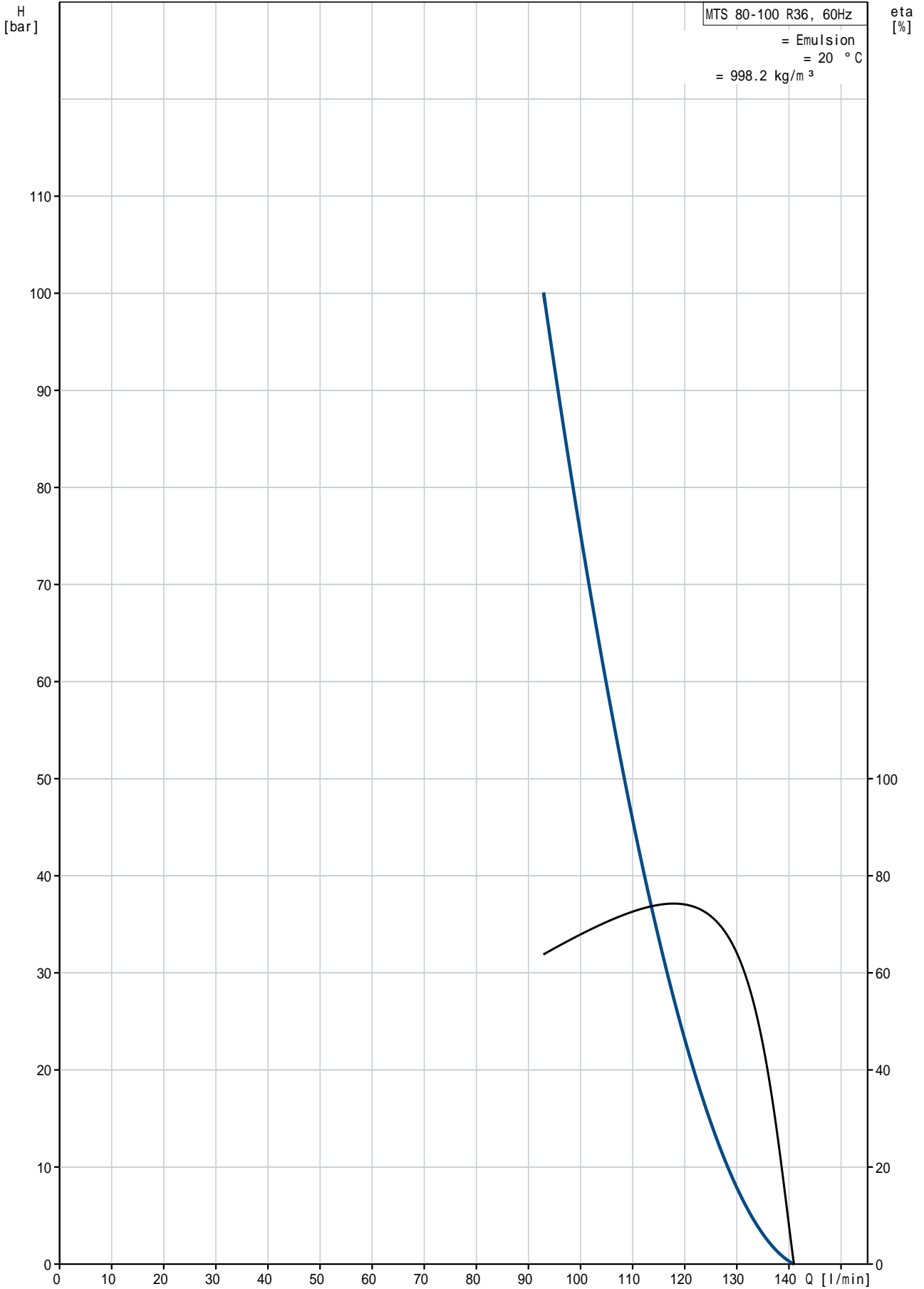

MTS 80-100 R36 DQ 60 Hz

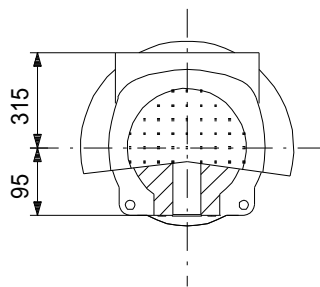
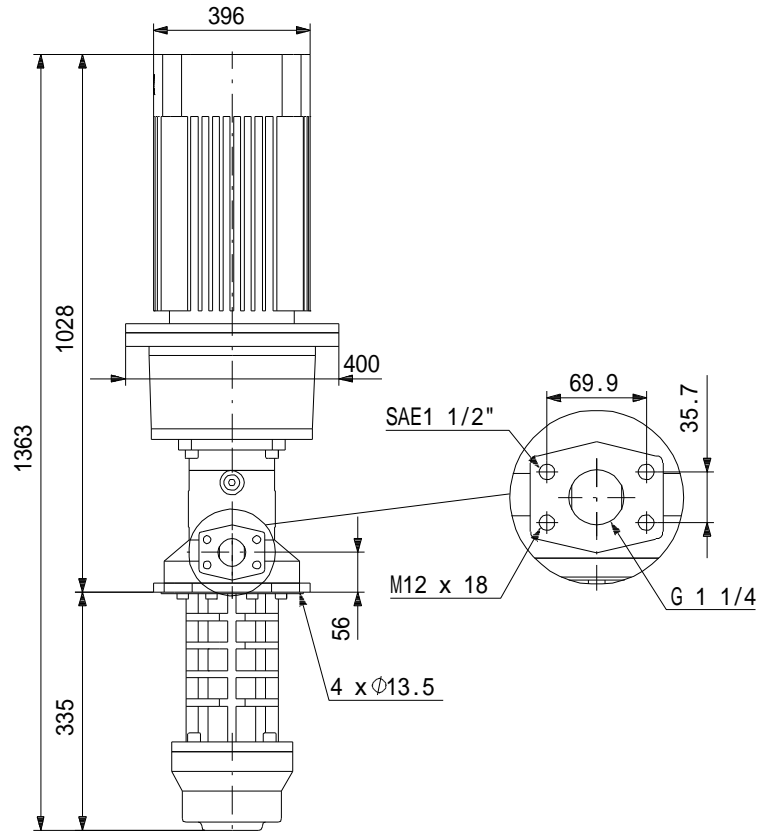

!

[mm]

MTS 80-100 R36 DQ 60 Hz

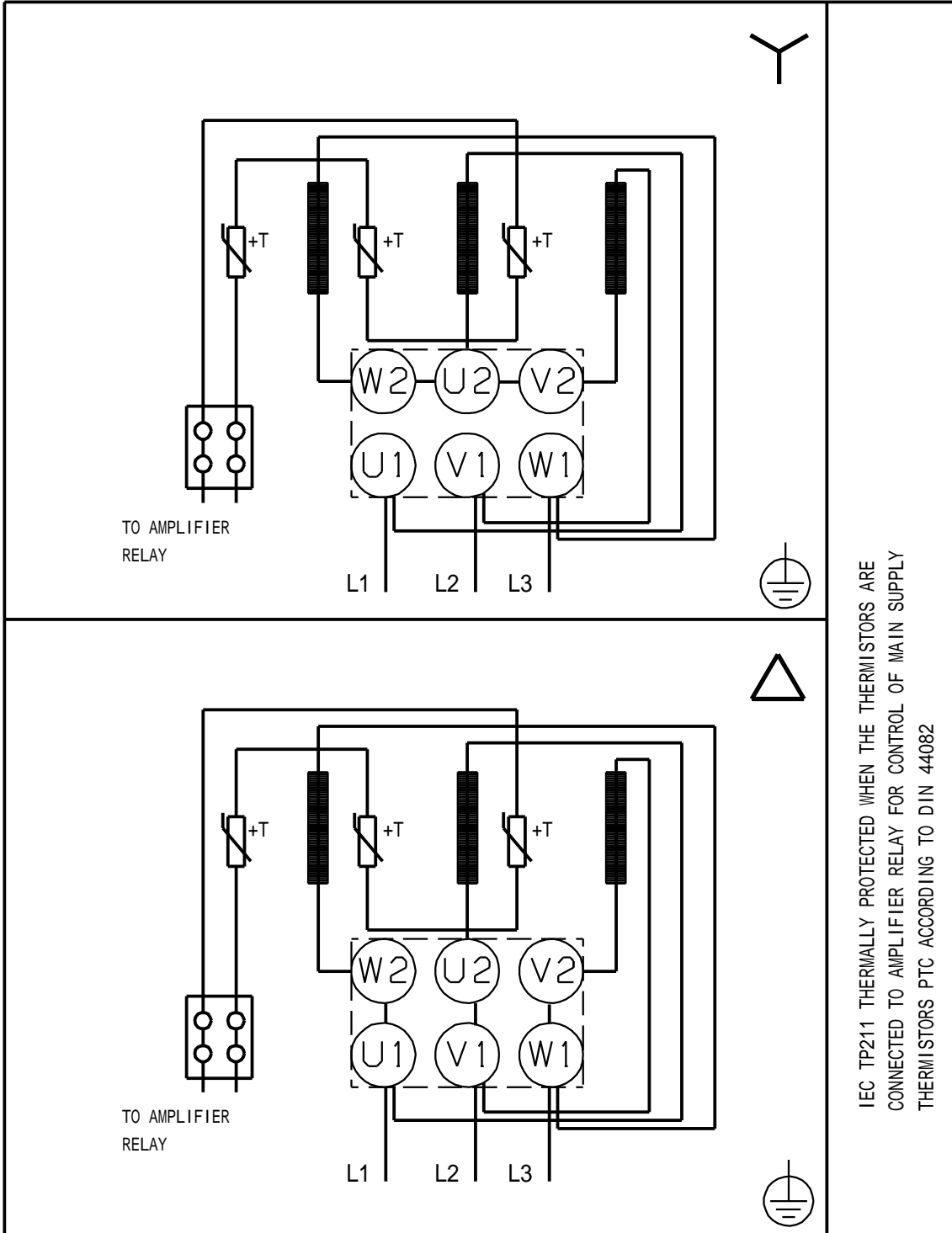

IEC TP211 THERMALLY PROTECTED WHEN THE THERMISTORS ARE
CONNECTED TO AMPLIFIER RELAY FOR CONTROL OF MAIN SUPPLY
THERMISTORS PTC ACCORDING TO DIN 44082