

1 MTS 20-30 R46 DQ



Screw spindle pump designed for pumping of cooling lubricants and cutting oils water/oil emulsion min. 3% for machine tool applications. The pump is designed to be mounted on top of tanks with pump immersed in the pumped liquid.

The pump has the following characteristics:

- High efficiency ensures very low heat input into the cooling lubricant.
- Axial thrust completely neutralised hydrostatically.
- Very wear resistant due specially hardened surfaces.
- DQ - shaft seal ring.
- Power transmission via cast iron flexible coupling.

The motor is a 3-phase AC motor.

:	:	Emulsion
:	:	80 °C
:	:	20 °C
:	:	998.2 kg/m ³
:	:	
:	가	: 3500 rpm
:	:	40.4 l/min
1	:	DQ
가:	:	CE,EAC
:	:	
:	:	60 °C
:	:	30 bar
:	:	G1 1/4"
:	:	G 3/4" / SAE 1"
:	:	246 mm
:	:	FF215
:	:	
IE	:	100LC
:	:	IE2 - IE3
- P2:	:	3 kW
(P2):	:	2.9 kW
:	:	60 Hz
:	:	3 x 380-480 V
:	:	6.20-5.40 A
:	:	860-1100 %
cos phi -	:	0.91-0.84
:	:	3480-3530 rpm
:	:	IE2 87,5% - IE3 88,5%
:	:	87.5-88.5 %
3/4	:	88.0 %
1/2	:	87.7 %
:	:	2
(IEC 34-5):	:	55 Dust/Jetting

(IEC 85): F

:
: 52.7 kg

MTS 20-30 R46 DQ 60 Hz

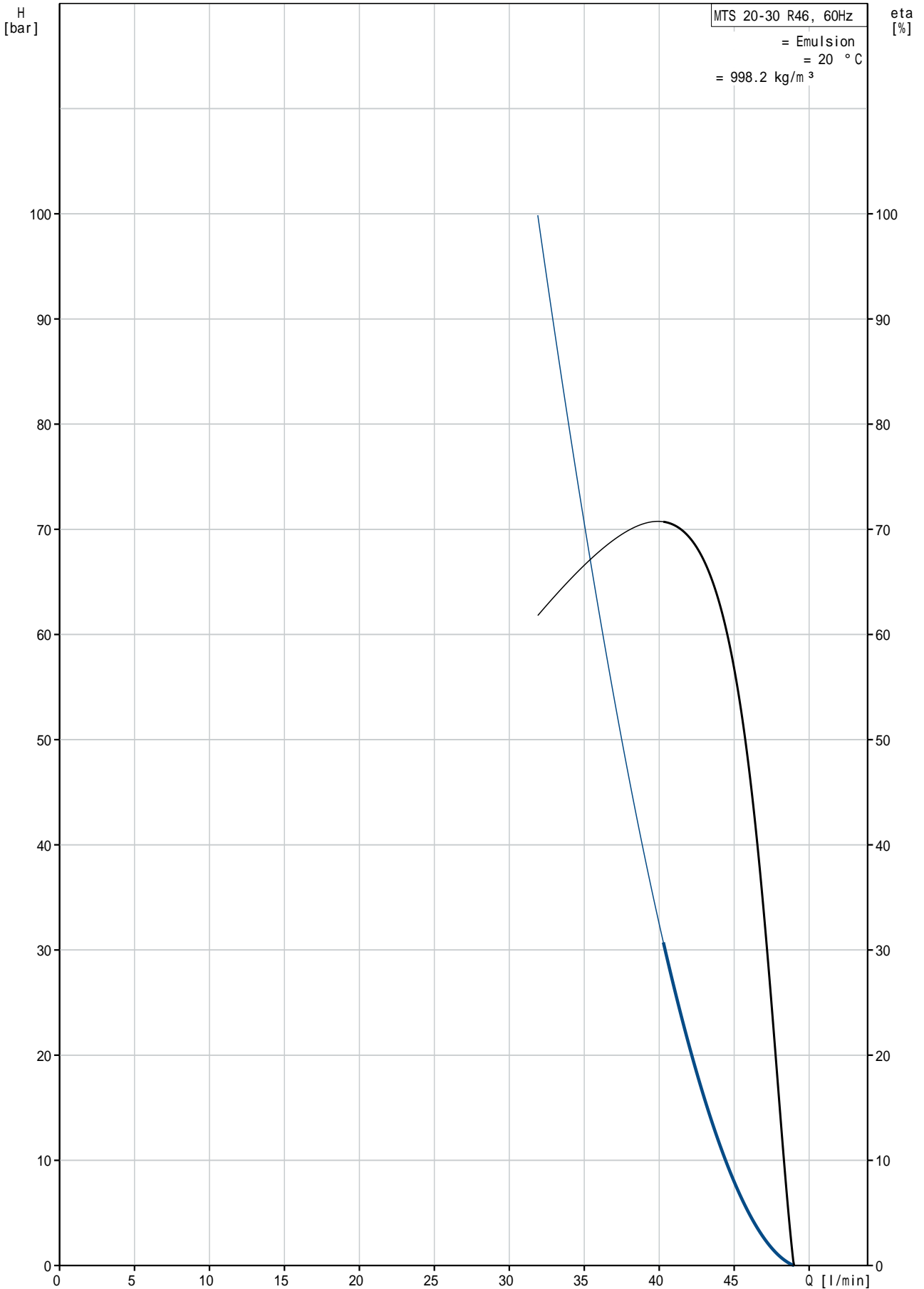

MTS 20-30 R46 DQ	
EAN	
가	: 3500 rpm
	: 40.4 l/min
1	: DQ
가:	CE,EAC
	A
	60 °C
	30 bar
	G1 1/4"
	G 3/4" / SAE 1"
	246 mm
	FF215
	Emulsion
	80 °C
	20 °C
	998.2 kg/m ³
	100LC
IE	: IE2 - IE3
- P2:	3 kW
(P2):	2.9 kW
	60 Hz
	3 x 380-480D V
	6.20-5.40 A
	860-1100 %
cos phi -	: 0.91-0.84
	3480-3530 rpm
	IE2 87,5% - IE3 88,5%
	87.5-88.5 %
3/4	: 88.0 %
1/2	: 87.7 %
	2
(IEC 34-5):	55 Dust/Jetting
(IEC 85):	F
	PTC
	87272297
Pos term	: 12 o'clock
	52.7 kg
	3 %
	46

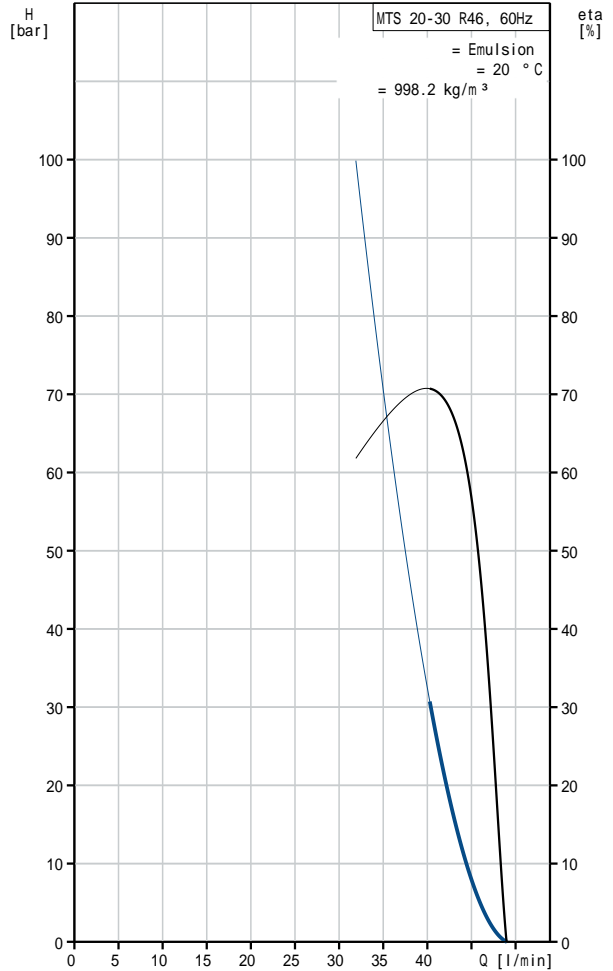

MTS 20-30 R46 DQ 60 Hz

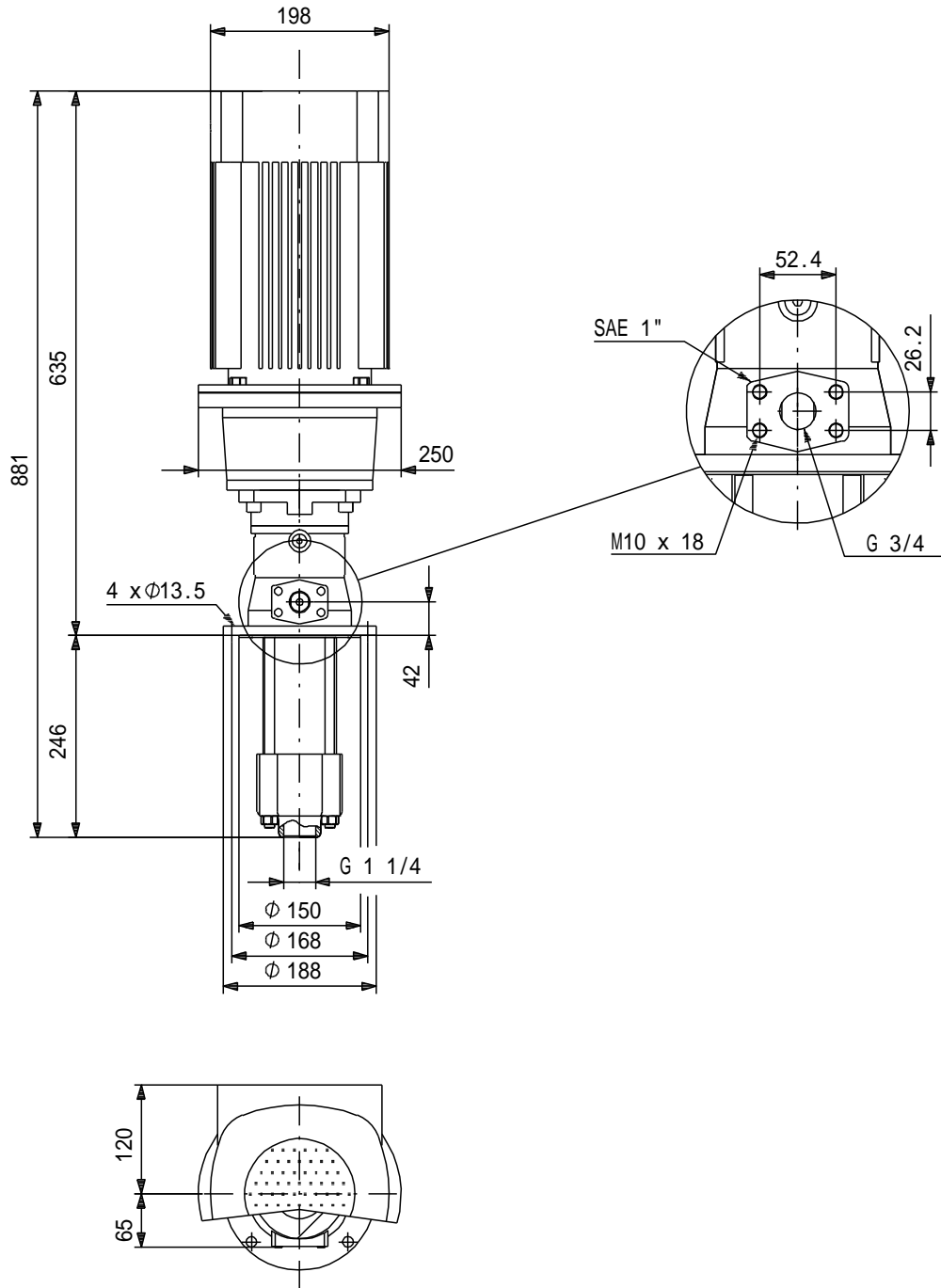

!

[mm]

MTS 20-30 R46 DQ 60 Hz

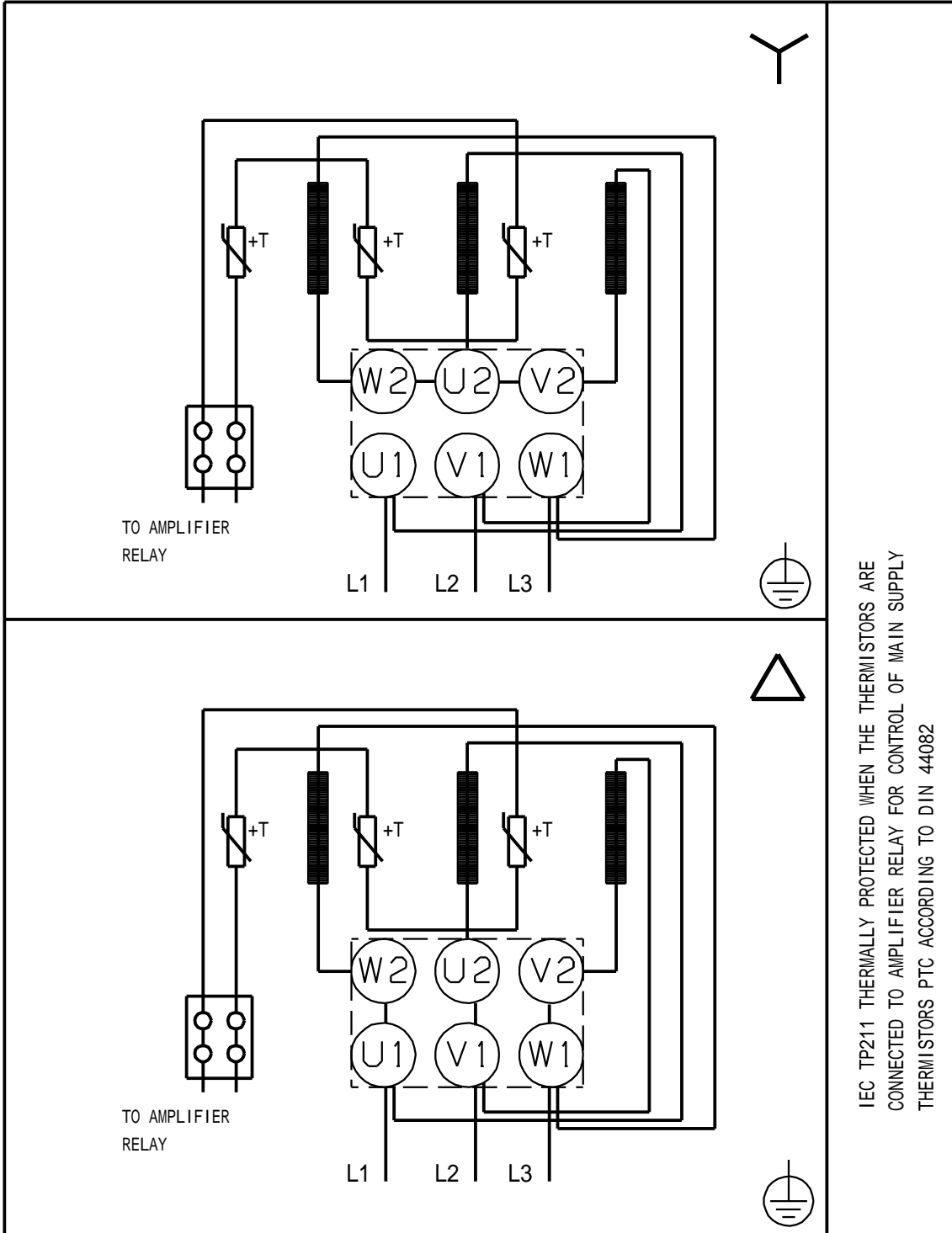

IEC TP211 THERMALLY PROTECTED WHEN THE THERMISTORS ARE CONNECTED TO AMPLIFIER RELAY FOR CONTROL OF MAIN SUPPLY THERMISTORS PTC ACCORDING TO DIN 44082