

1 MTS 140-40 R39 DQ



Screw spindle pump designed for pumping of cooling lubricants and cutting oils water/oil emulsion min. 3% for machine tool applications. The pump is designed to be mounted on top of tanks with pump immersed in the pumped liquid.

The pump has the following characteristics:

- High efficiency ensures very low heat input into the cooling lubricant.
- Axial thrust completely neutralised hydrostatically.
- Very wear resistant due specially hardened surfaces.
- DQ - shaft seal ring.
- Power transmission via cast iron flexible coupling.

The motor is a 3-phase AC motor.

:	:	Emulsion
:	:	80 °C
:	:	20 °C
:	:	998.2 kg/m <sup>3</sup>
:	:	
:	가	: 3500 rpm
:	:	222 l/min
1	:	DQ
가:	:	CE,EAC
:	:	
:	:	60 °C
:	:	40 bar
:	:	G2"
:	:	G 1 1/4" / SAE 1 1/2"
:	:	386 mm
:	:	FF300
:	:	
:	:	180MB
IE	:	NEMA Premium / IE3 60Hz
	- P2:	22 kW
	(P2):	18.5 kW
	:	60 Hz
	:	3 x 380-480D/660-690Y V
	:	40,0-32,5/23,0-22,2 A
	:	650-1040 %
cos phi -	:	0.91-0.91
:	:	3520-3560 rpm
:	:	IE3 91,7%
	:	91.7 %
3/4	:	93.7 %
1/2	:	94.4 %
:	:	2
	(IEC 34-5):	55 Dust/Jetting



### MTS 140-40 R39 DQ 60 Hz

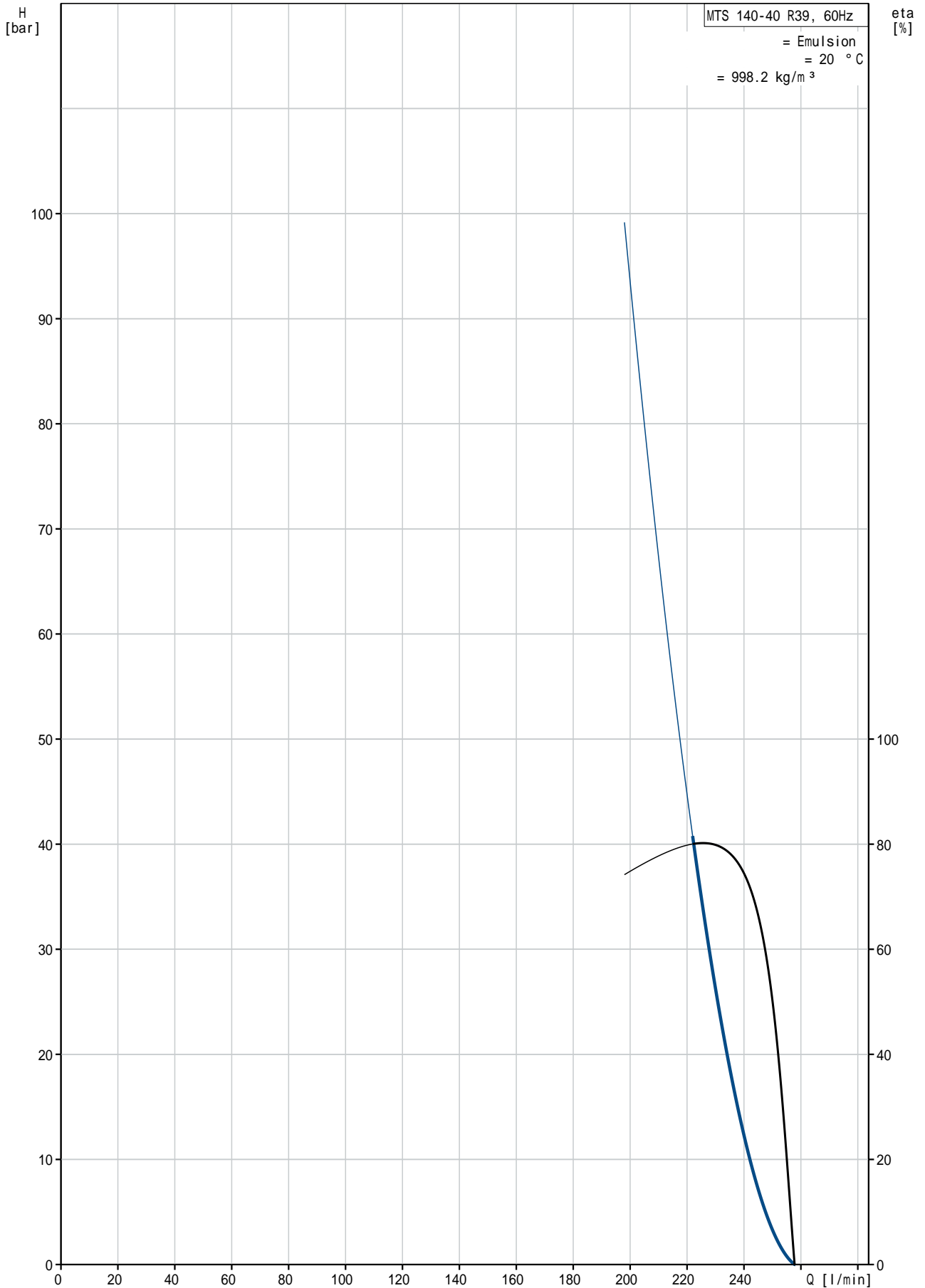

MTS 140-40 R39 DQ	
EAN	
가	3500 rpm
	222 l/min
1	DQ
가:	CE, EAC
	A
	60 °C
	40 bar
	G2"
	G 1 1/4" / SAE 1 1/2"
	386 mm
	FF300
	Emulsion
	80 °C
	20 °C
	998.2 kg/m <sup>3</sup>
	180MB
IE	NEMA Premium / IE3 60Hz
- P2:	22 kW
(P2):	18.5 kW
	60 Hz
	3 x 380-480D/660-690Y V
	40,0-32,5/23,0-22,2 A
	650-1040 %
cos phi -	0.91-0.91
	3520-3560 rpm
	IE3 91,7%
	91.7 %
3/4	93.7 %
1/2	94.4 %
	2
(IEC 34-5):	55 Dust/Jetting
(IEC 85):	F
	PTC
	87470021
Pos term	12 o'clock
	202 kg
	3 %
	39

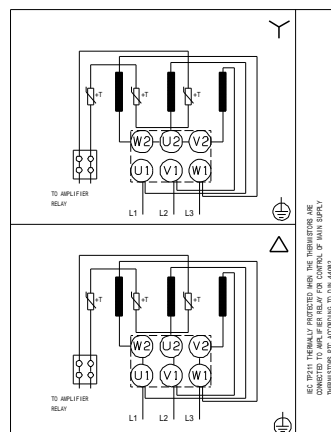
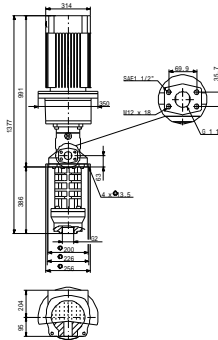
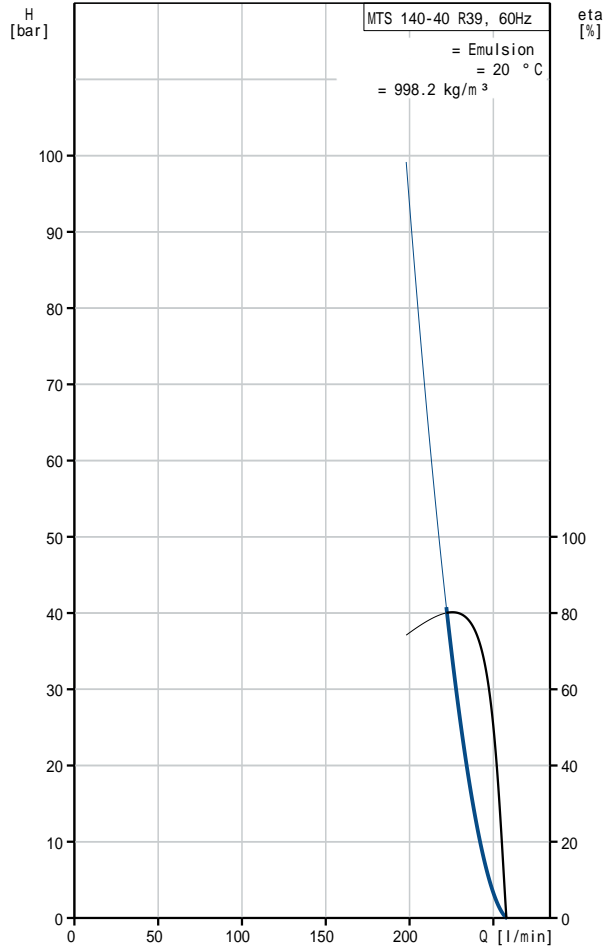

MTS 140-40 R39 DQ 60 Hz

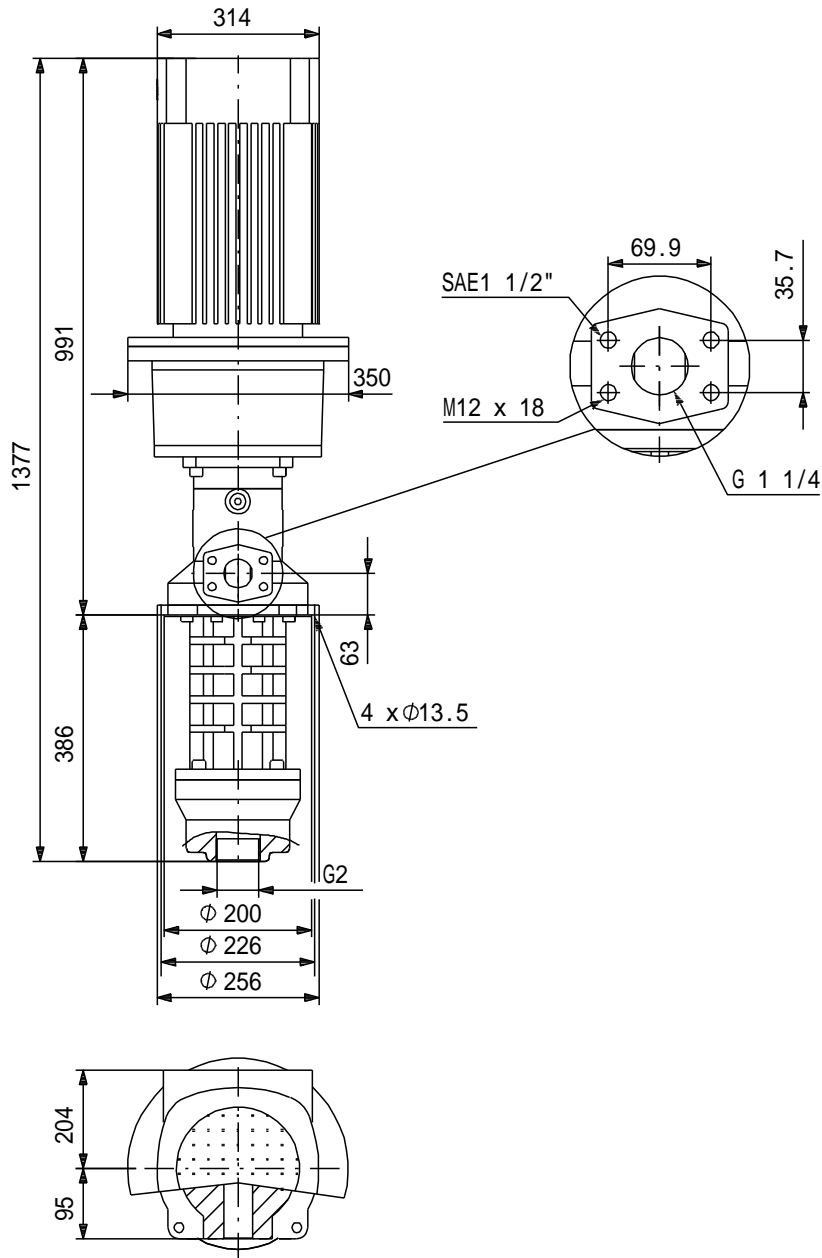

!

[mm]

MTS 140-40 R39 DQ 60 Hz

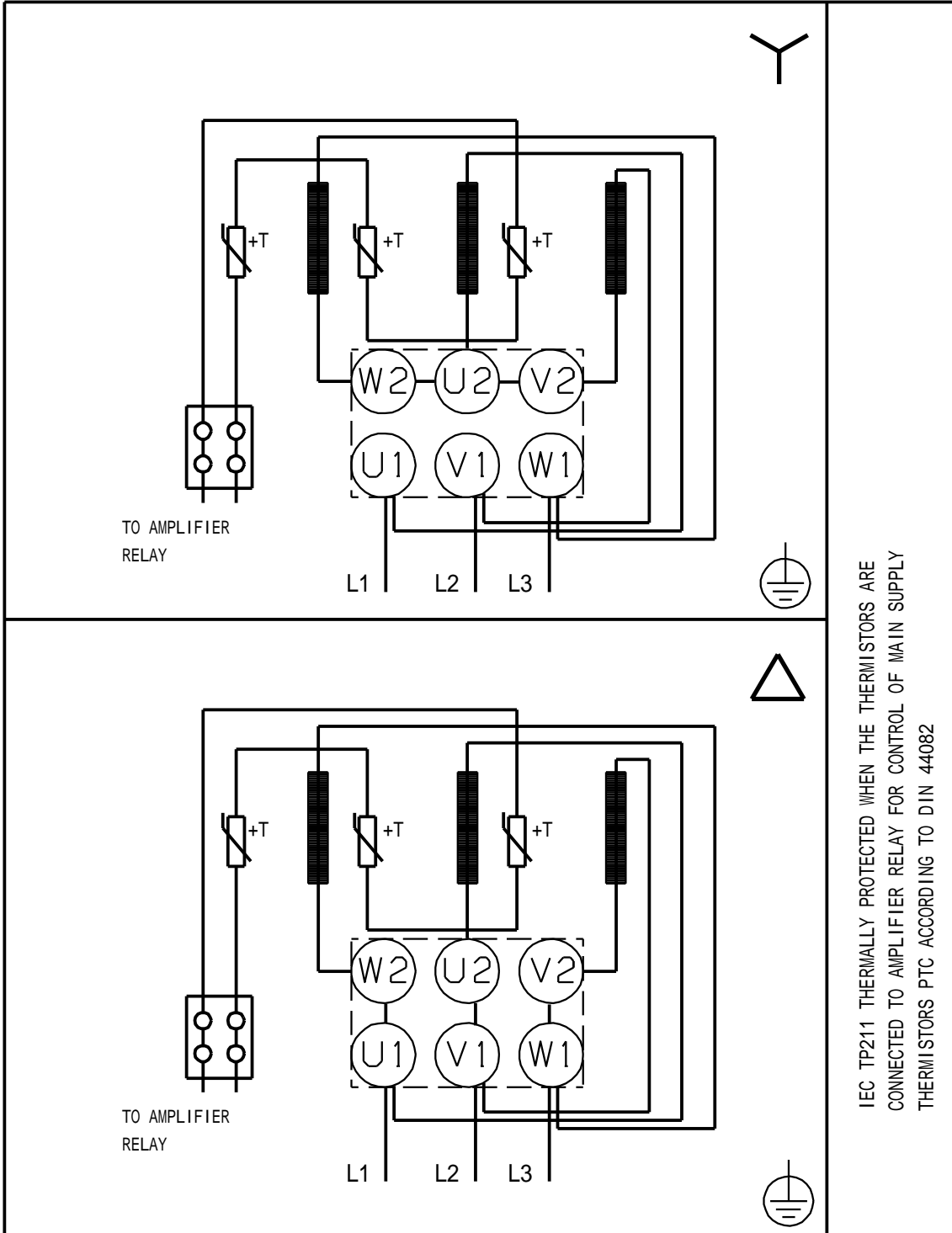

IEC TP211 THERMALLY PROTECTED WHEN THE THERMISTORS ARE  
CONNECTED TO AMPLIFIER RELAY FOR CONTROL OF MAIN SUPPLY  
THERMISTORS PTC ACCORDING TO DIN 44082